



## The Game of Sweet Revenge

AGE 6+/For 2 to 4 Players

### Object

To be the first player to get both of your colored pawns from your color START to your color HOME.

### Equipment

SORRY! Game Unit • 8 Pawns

### Setup

- Slide the latch marked "Open" on the product lid to release the four corner flaps. Fold the flaps out to form the playing board.
- Each player picks 2 matching color pawns and puts them in the START space holes that match in color.
- Set aside any extra pawns, out of play, or place them in their START space and leave them there.
- The youngest player goes first. Play passes to the left.

### Gameplay

On your turn:

Spin the spinner... what shows in the window? Move your pawn (if you can!) according to what you spun:

+1/ENTER 1	Either move one pawn forward 1 space OR move one pawn from START out onto the track.
+2 And Go Again/ ENTER 1 And Go Again	Either move one pawn forward 2 spaces OR move one pawn from START out onto the track. Whichever you do, GO AGAIN.
+3	Move one pawn forward 3 spaces.
-4	Move one pawn backwards 4 spaces.
+5	Move one pawn forward 5 spaces.
+7/SPLIT	Either move one pawn forward 7 spaces OR split the move between your two pawns. May NOT be used to start a pawn!
+8	Move one pawn forward 8 spaces.
+10/-1	Either move one pawn forward 10 spaces OR move one pawn backwards 1 space.
+11/SWITCH	Move one pawn forward 11 spaces OR switch any one of your pawns (that are not at START) with one pawn of an opponent. NOTE: Forfeit your move if you don't want to change places and it is impossible to go forward 11 spaces.
+12	Move one pawn forward 12 spaces.
SORRY!®	Take one pawn from your START, place it on any space that is occupied by an opponent, and return that opponent's pawn to its START. If there is no pawn in your START or no opponent's pawn on any space, you forfeit your move.

The spinner instructions are straightforward, but a few things can happen that need further explanation.

**Enter a Pawn:** You may only leave START and enter the board by spinning either the +1/ENTER 1 or +2 And Go Again/ ENTER 1 And Go Again. If another pawn is on the your START space, BUMP it back to its own START.

**Bumping:** Land on a space already occupied by another player's pawn and you BUMP that pawn back to its own color START space. WARNING: Careful... you could bump yourself back!

**Moving Backwards:** Spin -4 or -1 and you move backwards. Any player who has successfully moved backwards at least two spaces beyond his/her START space may, on a subsequent turn, move into his/her own SAFETY ZONE — and towards HOME! — without moving all the way around the board.

**Slide:** Land on the first space of a SLIDE that's NOT your color and move all the way to the end of it, bumping any pawn(s) in your way back to its own START space(s). Land on a SLIDE of your own color, and you don't slide

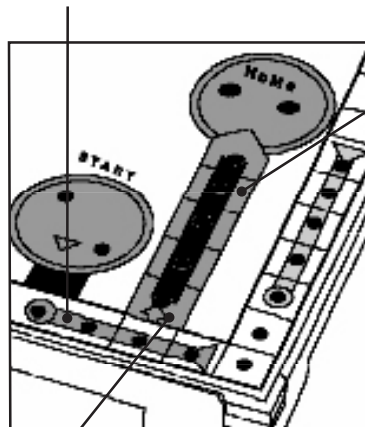

**Safety Zone:** Only you may enter your own color SAFETY ZONE. All other rules apply. No pawn may enter its SAFETY ZONE by a backward move; however, a pawn may move backwards out of its SAFETY ZONE and on a subsequent turn, move back into the ZONE if the spinner allows. Once you're in your SAFETY ZONE, no one can move you out of it!

**Safety Zone Entry Space:** When moving along the outside track, you may not move your pawn forward beyond your own SAFETY ZONE ENTRY. However, you may pass the Entry space on a backwards move (4 or 10) or as a result of a "SORRY!" or "switch" played against you.

**Home:** You must bring each of your two pawns into HOME by exact count! Once HOME, do not move that pawn again for the rest of the game.

### Winning

The first player to get both of his/her pawns from START to HOME wins!



Not suitable for children under 3 years because of small parts - choking hazard

We will be happy to hear your questions or comments about this game. US consumers please write to: Hasbro Games, Consumer Affairs Dept., P.O. Box 200, Pawtucket, RI 02862. Tel: 888-836-7025 (toll free). Canadian consumers please write to: Hasbro Canada Corporation, 2350 de la Province, Longueuil, QC Canada, J4G 1G2. European consumers please write to: Hasbro UK Ltd., Hasbro Consumer Affairs, P.O. BOX 43, Caswell Way, Newport, Wales, NP194YD, or telephone our Helpline on 00 800 2242 7276.



©2005 Hasbro, Pawtucket, RI 02862. All Rights Reserved. TM and © denote U.S. Trademarks.



[parkerbrothers.com](http://parkerbrothers.com)